

## Multi-Turn Absolute Rotary Encoder

Housing Dia.:58mm; Solid Shaft Dia.:10mm;

Output: **DeviceNet**; Resolution: Multi-turn Max.12bits turns, Single Turn Max.13bits;

**GMA-D Series**

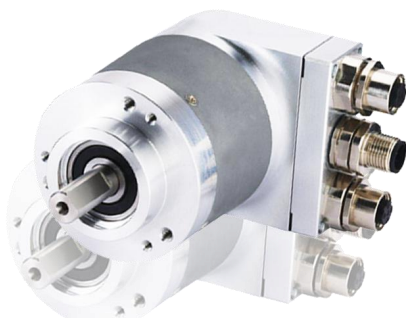

- ▶Housing Diameter:58mm;
- ▶Solid/hollow Shaft Diameter:10mm;
- ▶Output: DeviceNet;
- ▶Resolution: Multi-turn Max.12bits turns, Single Turn Max.13bits;
- ▶Supply Voltage:5v,8-29v;
- ▶Widely used in various fields of automatic control and measurement system,such as machinery manufacturing, shipping, textile, printing, aviation, military industry Testing machine, elevator, etc.
- ▶Vibration-resistant, corrosion-resistant, pollution-resistant;



### Product characteristics

Housing Dia.:	58mm
Solid Shaft Dia.:	10mm

### Electrical Data

Resolution:	Max.16bits, Single turn max.16bits, Total Max.29bits
Interface:	DeviceNet
Supply Voltage:	8-29V
Max. Frequency Response	30Khz

### Mechanical Data

Start Torque	0.01N•M
Max. Shaft Loading	Axial: 5-30N, Radial:10-20N;
Max. Rotary Speed	6000rpm
Weight	160-200g

### Environment Data

Working Temp.	-30~80℃
Storage Temp.	-40~80℃
Protection Grade	IP65

### Ordering Code

#### Multi-Turn Absolute Encoder

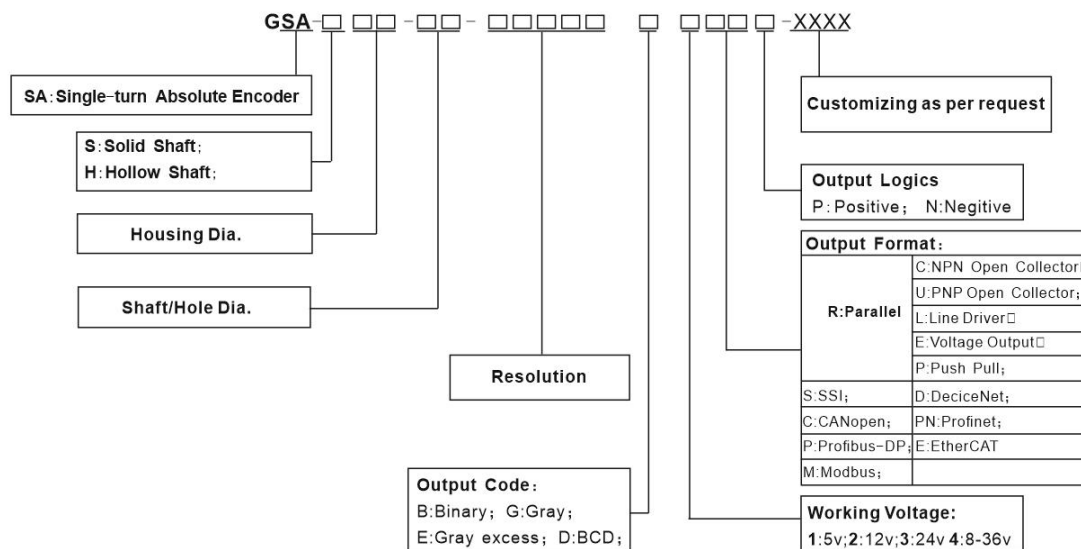

### Dimensions

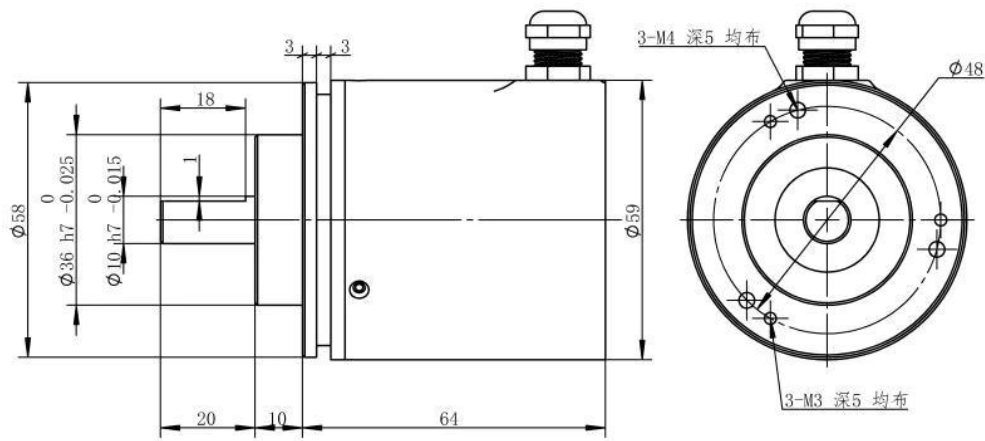

**Note:**

- ▶ Adopt elastic soft connection shall be applied between encoder shaft and output shaft of user end to avoid damage of encoder shaft system due to serial movement and run out of user shaft.
- ▶ Please pay attention to the allowable axle load during installation.
- ▶ Make Sure that the difference Between Axial Degree of encoder shaft and user output shaft shall be no more than 0.20mm, and the deviation angle with axis shall be less than 1.5 °.
- ▶ Try to avoid knocking and falling collision during installation;
- ▶ Do not connect the power line and the ground wire in reverse.
- ▶ The GND wire shall be as thick as possible, generally larger than  $\phi 3$ .
- ▶ Output lines of encoder shall not be overlapped with each other to avoid damaging output circuit.
- ▶ Signal line of encoder shall not be connected to DC power supply or AC current to avoid damaging output circuit.
- ▶ The motor and other equipment connected to the encoder shall be well grounded without static electricity.
- ▶ Shielded cable shall be used for wiring.
- ▶ Before starting the machine, carefully check whether the wiring is correct.
- ▶ During long-distance transmission, the signal attenuation factor shall be considered, and the output mode with low output impedance and strong anti-interference ability shall be selected.
- ▶ Avoid using in strong electromagnetic wave environment.