

Incremental Rotary Encoder

Mini Size

Housing Dia.:100mm;

Hollow Shaft Dia.:30,32,38,40,45mm;

GI-H100 Series



- ▶ Housing Diameter:100mm;
- ▶ Hollow Shaft Diameter:30,32,38,40,45mm;
- ▶ Resolution: Max.6000ppr;
- ▶ Supply Voltage:5v,8-29v;
- ▶ Output Format: NPN/PNP open collector, Push pull, Line Driver;
- ▶ Output Signal: A B / A B Z / A B Z & A- B- Z-;
- ▶ Widely used in various fields of automatic control and measurement system,such as machinery manufacturing, shipping, textile, printing, aviation, military industry Testing machine, elevator, etc.
- ▶ Vibration-resistant, corrosion-resistant, pollution-resistant;

Product characteristics

Housing Dia.:	100mm
Hollow Shaft Dia.:	30,32,38,40,45mm

Electrical Data

Resolution:	Max.6000ppr
Output Format:	NPN/PNP open collector, Push pull, Line Driver, Voltage Output;
Output Signal:	A/A B / A B Z / A B Z & A- B- Z-;
Supply Voltage:	5V, 8-29V
Max. Frequency Response	300Khz

	Open Collector	Voltage Output	Line Driver	Push Pull
Consumption current	≤ 80mA;	≤ 80mA;	≤ 150mA;	≤ 80mA;
Load current	40mA;	40mA;	60mA;	40mA;
VOH	Min.Vcc x 70%;	Min.Vcc - 2.5v	Min.3.4v	Min.Vcc - 1.5v
VOL	Max.0.4v	Max.0.4v	Max.0.4v	Max.0.8v

Mechanical Data

Start Torque	1 N•M
Max. Shaft Loading	Axial: 10N, Radial:20N;
Max. Rotary Speed	5000rpm
Weight	200g

Environment Data

Working Temp.	-30~80°C
Storage Temp.	-40~80°C
Protection Grade	IP54

Wave Form

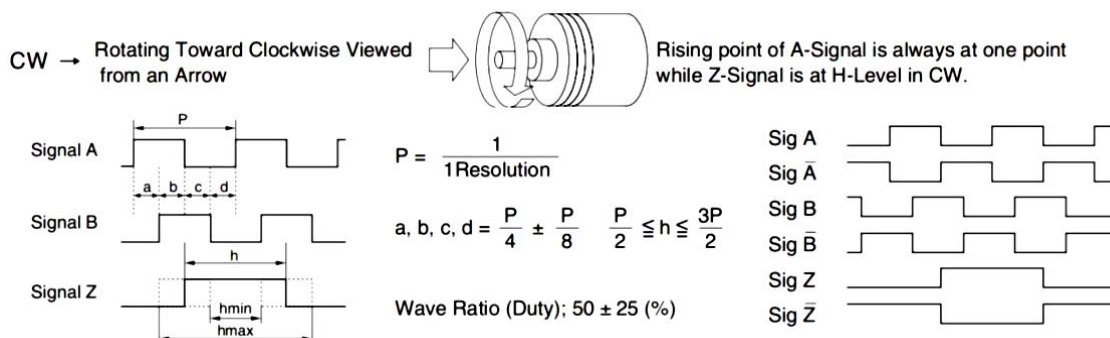

Circuit of Output Signal

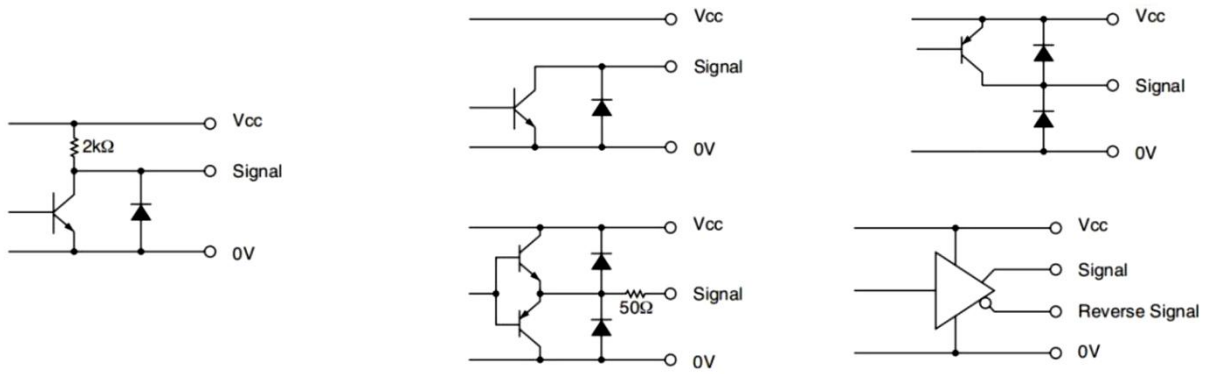

Ordering Code

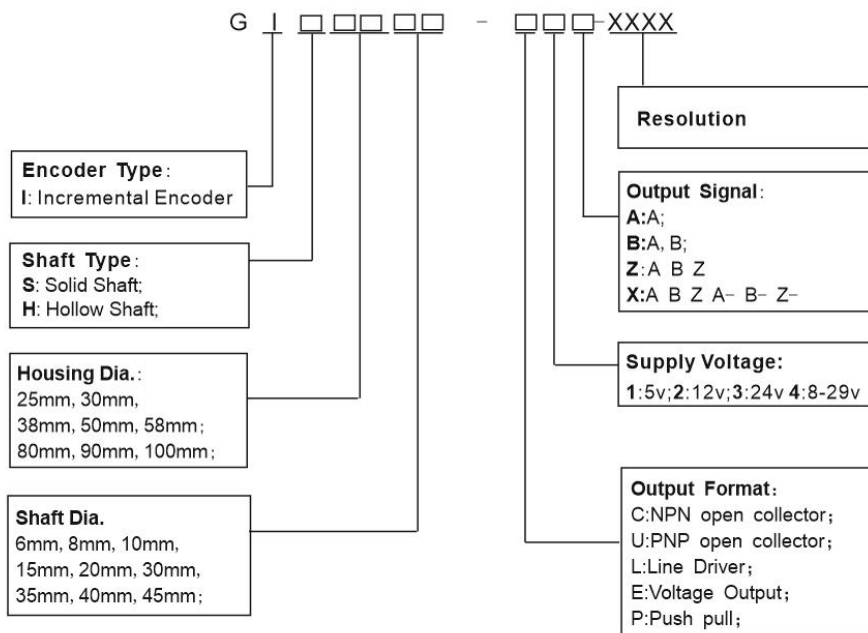

Dimensions

